

TV-Web-Telco integration: the next convergence frontier

4th GI/ITG KuVS Fachgespräch on NGN SDPs

Enzo Scotto (speaker) Heiner Grusdt, M. Lott
Nokia Siemens Networks
CTO Research – Munich
31.03.2011

Agenda

TV-Web-Telco (TWT) convergence motivation

End user's vision

Relevant standards

Product on the market: NSN Ubiquity

Proposed architecture

Conclusions and further work

TV-Web-Telco (TWT) convergence motivation

Internet changes industries and user experience

Internet players
 Internet user experience
 New business models



Telco2web

- GSMA openAPI
- App stores (smartphone apps)
- Web technologies for telco apps

Web TV content
 Social TV
 New TV platforms
 eHome
 Web enabled TV devices



Web-TV

- App stores (TV apps)
- Multiscreen, personalization
- Blended web content

Think convergent: TWT

End user's vision



One person

Many devices

Many scenarios

One user experience

Standardization (1)



ETSI integrated

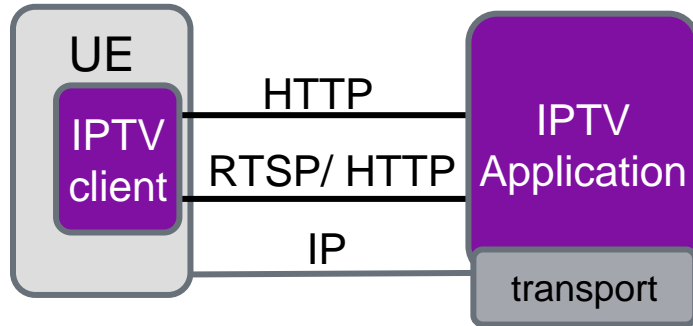

ETSI IMS based

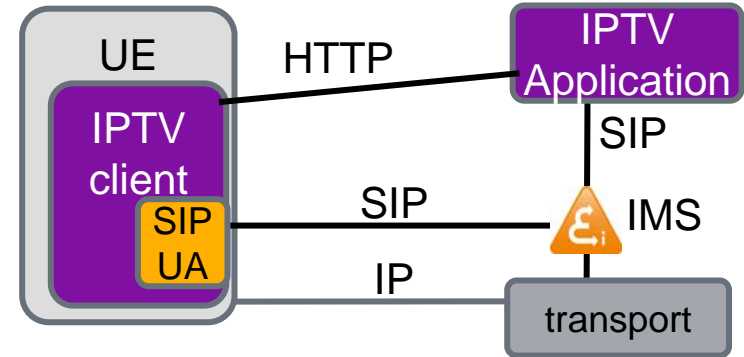

- Two alternatives:
 - “NGN integrated”: RACS used for resource allocation
 - “IMS based”: tight IMS integration
- Limited industry uptake
- SIP interface to IPTV subsystem
- No support in network for web content

Open IPTV Forum

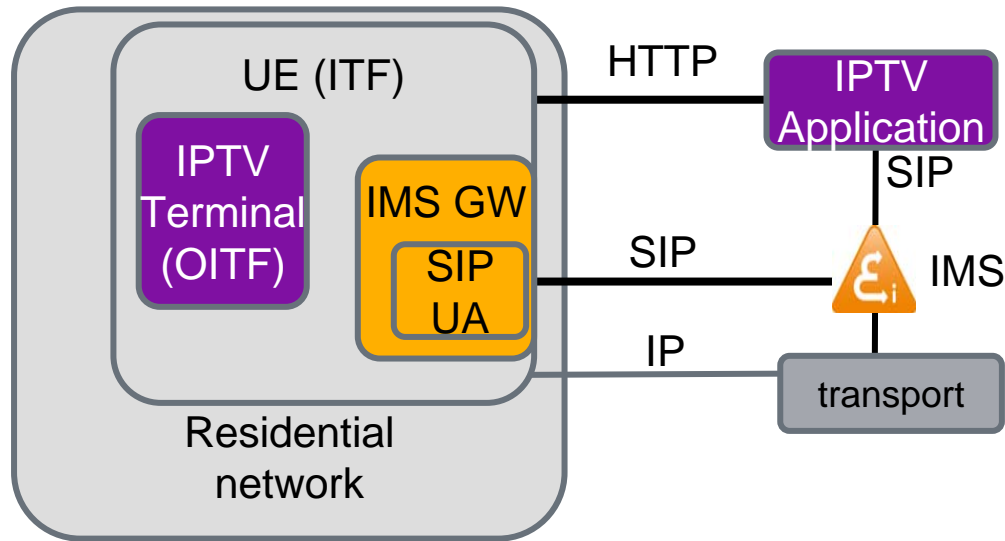

- Open architecture by separation of providers
 - access, service platform, IPTV, content
- Content via managed (IMS) or unmanaged (Internet) networks
- Home network with functional definition, to be flexibly allocated
- Runtime for apps on device
- **Standard in managed network scenario aligned with ETSI TISPAN**

Standardization (3)



IETF

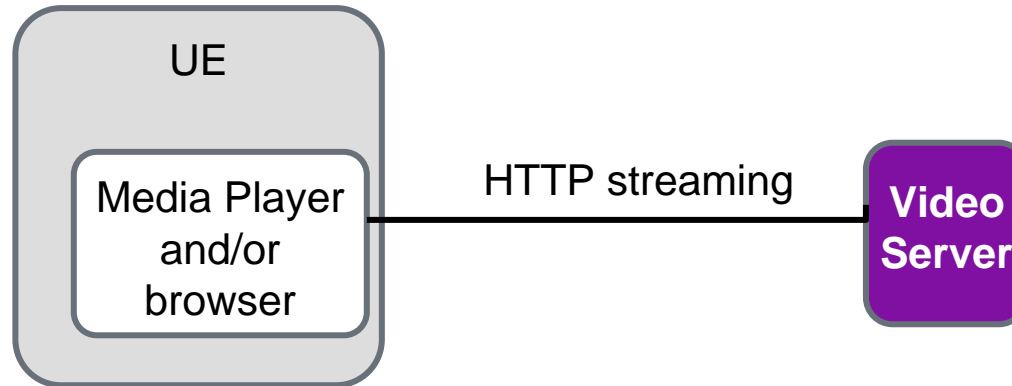

- HTTP streaming is a powerful solution for streaming **over Internet**
- Many (**incompatible**) variants exist: Microsoft, Apple, Adobe, Google
- H264 Scalable Video Coding addresses the gaps due server overhead and caching proxy (high number of small files)

Recently started IETF “Real Time Communication” (browser based) and existing W3C “TV interest group” to find synergies

Nokia Siemens Networks Ubiquity Multiscreen TV Platform

Any Network **Any Device** **Multiple Services** **Everywhere**

- 3G/LTE
- Internet
- WiFi hot spot
- Managed IP network
- Broadcast network

-  Smart Devices Mobile
-  Internet PC
-  Home TV STB
-  Game Consoles etc.

- One subscription, one bill
- Multi-Screen EPG Browsing & Interaction
- Multi-screen Live Channel Viewing
- Multi-screen VoD Catalogue
- Internet Social networks
- Variety of applications Blended Services



My personal media

One Media Delivery Solution

Source: Ubiquity launch at IBC 2010 – Nokia Siemens Networks



Uniquely delivering media to the widest variety of devices from a single service mediation platform

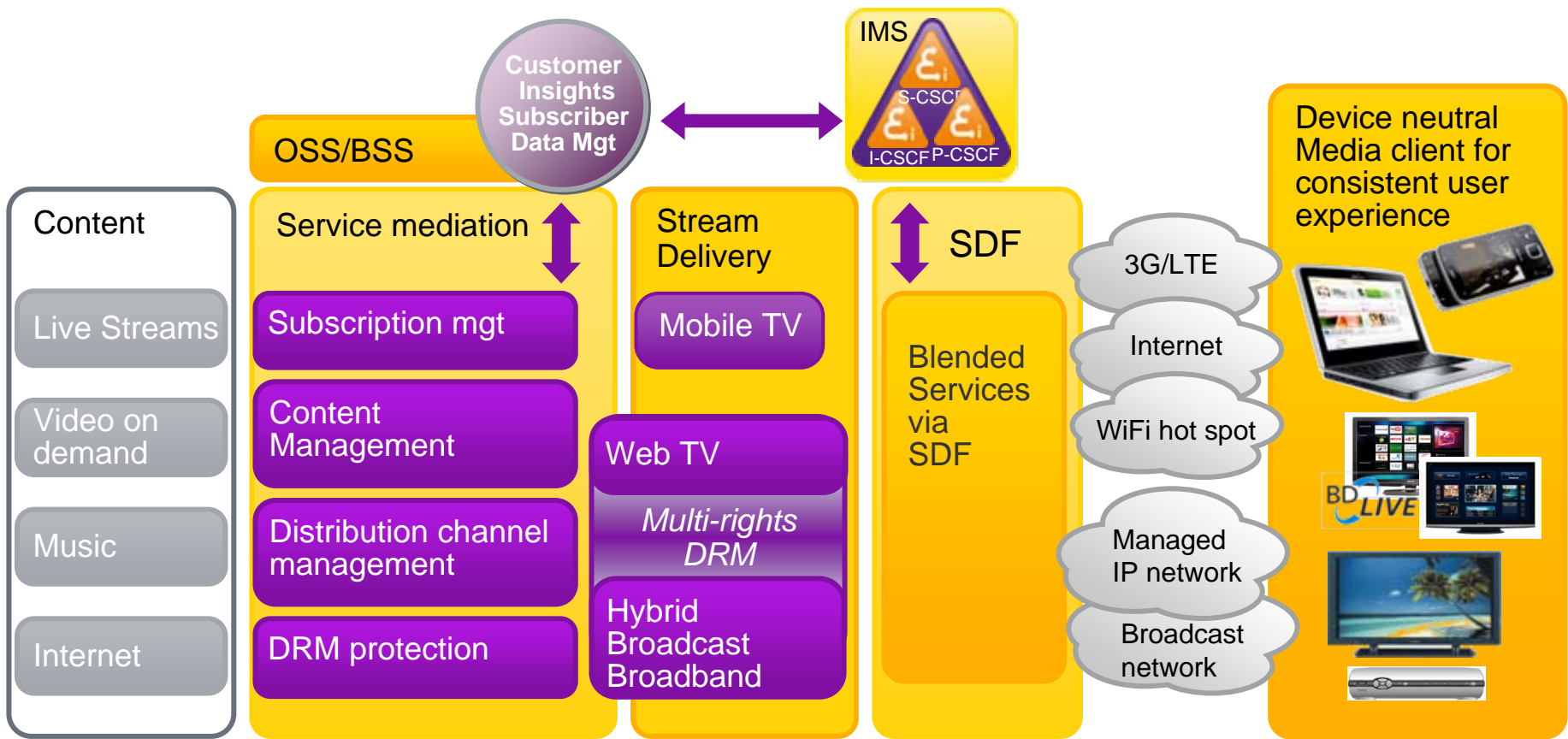

Cost Effective and Agile platform supporting rapid media market evolution

Source: Ubiquity launch at IBC 2010 – Nokia Siemens Networks



NSN Ubiquity client architecture



Driving Consolidation in client technologies

- Common multi-device middleware core (TV-OS)
- Leveraging Linux Open Source Media Projects
- Native support for OTT, DVB, DLNA, Telco Apps
- Multiple application frameworks support

Application Environment (HTML5, Flash, Qt...)

TVOS / Media Player

Application / Browser / Flash plug-in APIs

DRM

Media Formats
H.264, MPEG-2, AAC
MP4, 3GPP, MPEG-2 TS

PVR Engine

Remote Mgt

Streaming Protocols
HTTP, RTP, RTSP, IGMP,
DVB

DLNA UPnP
CIFS, DAAP

Porting Layer

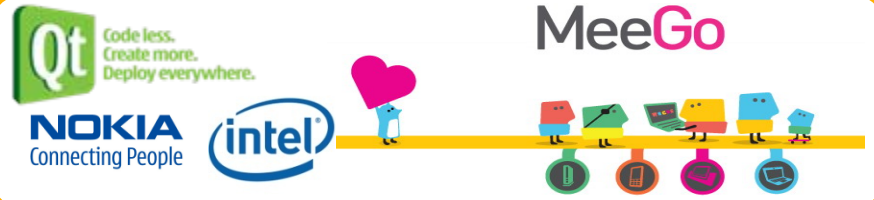

Source: Ubiquity launch at IBC 2010 – Nokia Siemens Networks



Proposed TWT solution: architecture

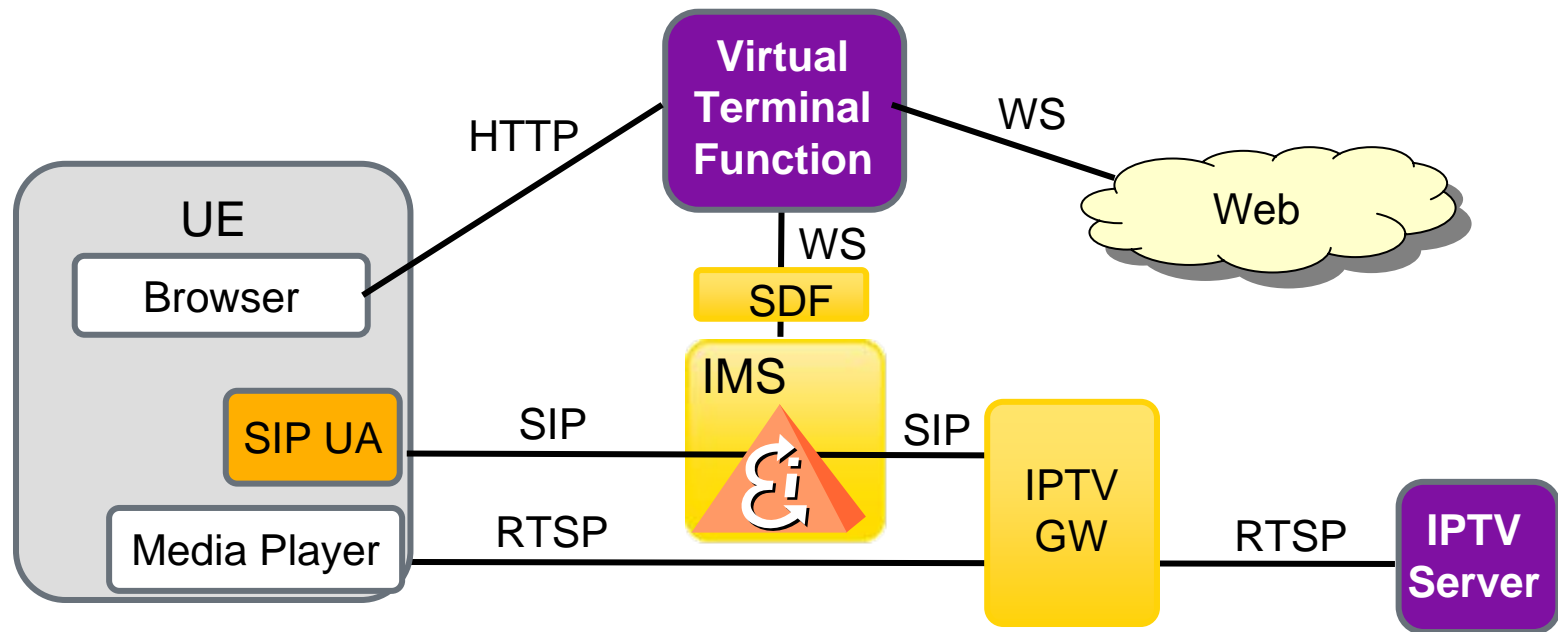

- The Virtual Terminal Function (VTF) to shift intelligence into the network
 - Implements the converged user experience in HTML/CSS/JS coded user interface, rendered in browser on the device
 - Interacts with TV, Web, Telco domains via Web Services
- The IPTV GW in operator domain coordinates SIP and RTSP, interfacing IPTV subsystem only via RTSP
- Media player on device is required for DRM and other features
- Extends the browser based approach in COMET project “APSINT” to IPTV

Proposed TWT solution: advantages

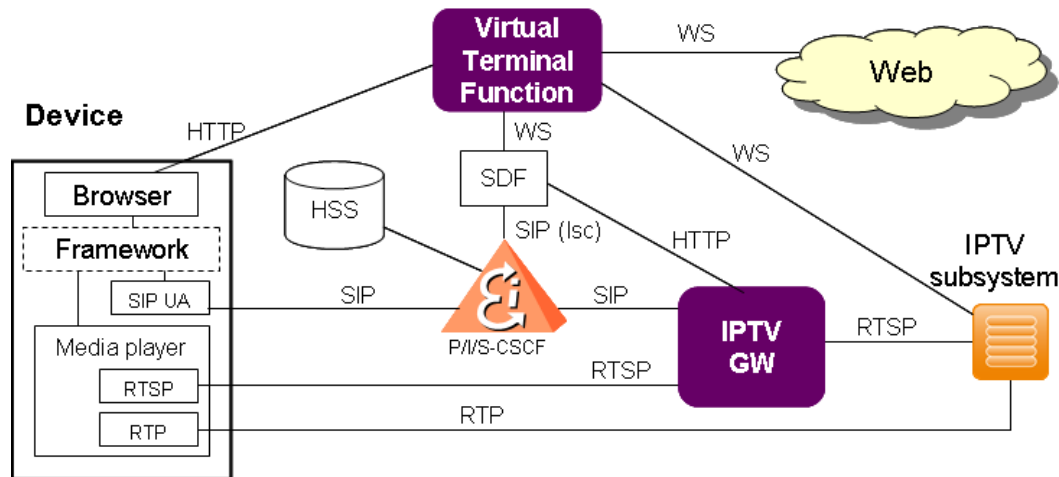

- TWT service benefits of the well known advantages of a web app
 - More effective support for multiscreen and personalization
 - Fast development and deployment of advanced use cases with multiple media flows terminated at different devices
 - Flexibility, web innovation speed
 - Simplified software management and interoperability due to lighter clients
- Virtual Terminal Function can be in operator's domain or in Internet domain, opening new positions for the operators in the value chain
- The IPTV GW
 - Ensures re-use of telco assets like for example resource control
 - Integrates with existing IPTV servers
 - Interfaces the device directly via RTSP to improve responsiveness in case of trick play commands

Proposed TWT solution: further work

- Closely follow up the IETF RTC and W3C TV interest group work
- Alternative based on IETF RTC solution: thin client
- Support of home network
- Experimental verification based on open source software
- Further relevant results from COMET project “APSINT” are expected

Conclusions

- The Internet “wind of change” blows in video content domain
 - Convergence all the way up to application layer
 - It is a much more complex ecosystem than in T2W
 - It is a fertile soil for innovation

What does it mean for operators ?

- New opportunities arise for telco assets
- Take a risk, make a change!

What does it mean for the end user ?

- New web oriented user experience in video consumption

NSN has flexible and innovative solutions:

- Product: Ubiquity
- Research project:
browser based TWT

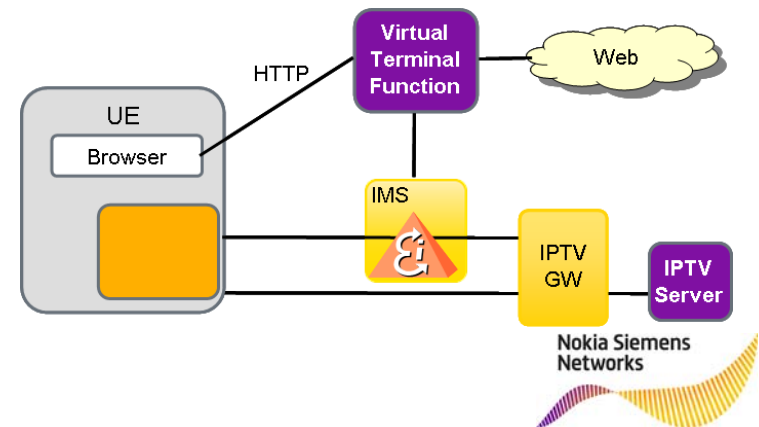

backup

Standardization (1)

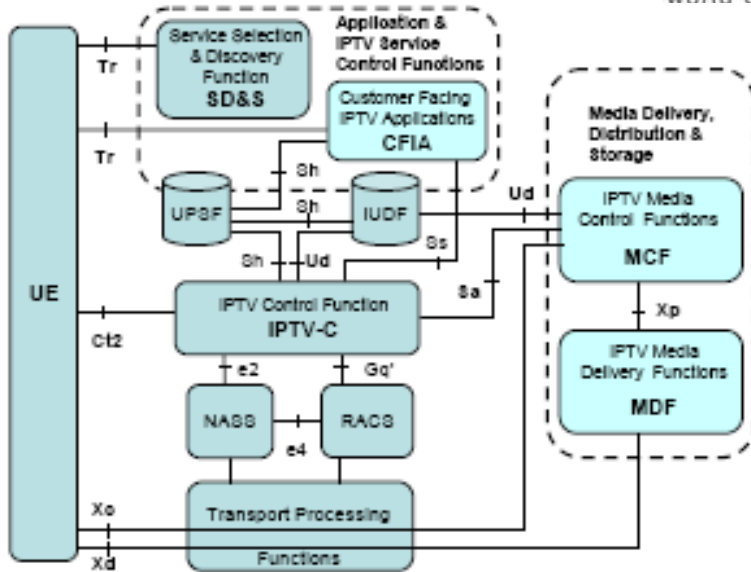

Fig. 2. Simplified TISPAN NGN dedicated IPTV subsystem functional architecture [5].

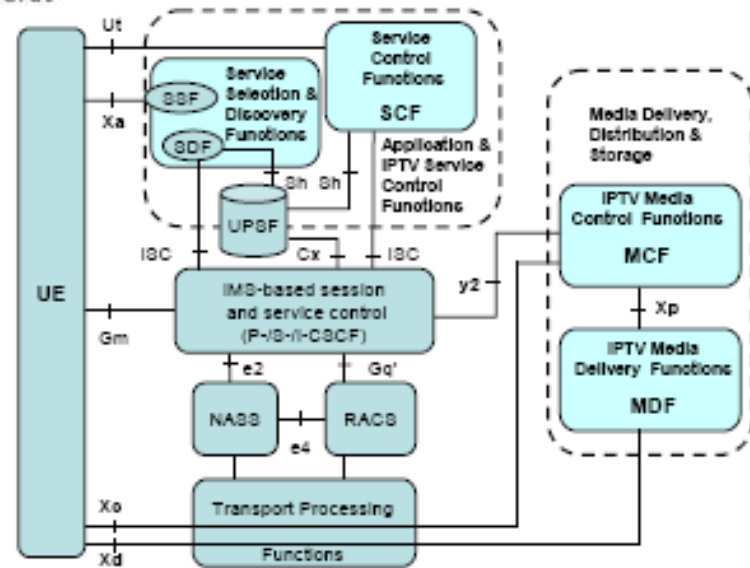
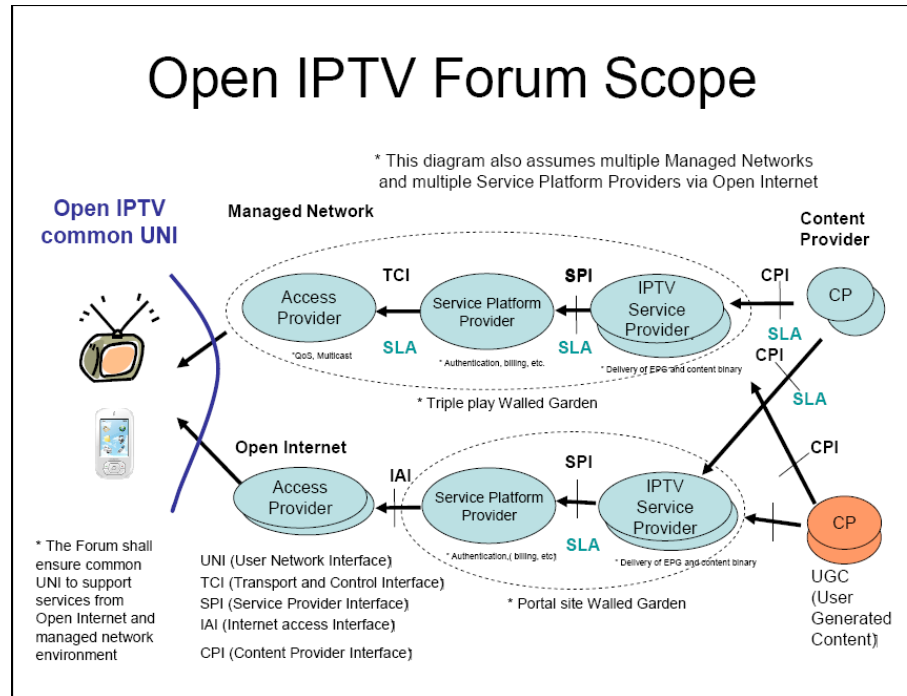

Fig. 3. Simplified TISPAN NGN IMS based IPTV functional architecture [6].

Source: Next Generation of Multimedia Services – NGN based IPTV architecture - E. Micoczy, T-Com Slovak Telekom

- Two alternatives:
 - “NGN integrated”: RACS used for resource allocation
 - “IMS based”: tight IMS integration
- Limited industry uptake
- SIP interface to IPTV subsystem
- No support in network for web content



- Open architecture by separation of providers
 - access, service platform, IPTV, content
- Content via managed (IMS) or unmanaged (Internet) networks
- Home network with functional definition, to be flexibly allocated
- Runtime for apps on device
- **Standard in managed network scenario aligned with ETSI TISPAN**

Standardization (3)

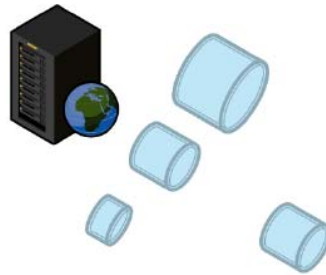

- Media is split up into a series of file chunks which are downloaded via plain HTTP
- If several bitrates are available, client can choose between chunks of different size

Typical chunk size = 2 seconds of video
(i.e. 250 KB for 1 Mbps video)



Source: "IIS smooth streaming: technical overview", fig. 2. A. Zambelli, March 2009 - Microsoft

- HTTP streaming is a powerful solution for streaming **over Internet**
- Many (**incompatible**) variants exist: Microsoft, Apple, Adobe, Google
- H264 Scalable Video Coding addresses the gaps due server overhead and caching proxy (high number of small files)
- IETF "Real Time Communication" (browser based) and W3C "TV interest group" to find synergies

openIPTVForum home network functions

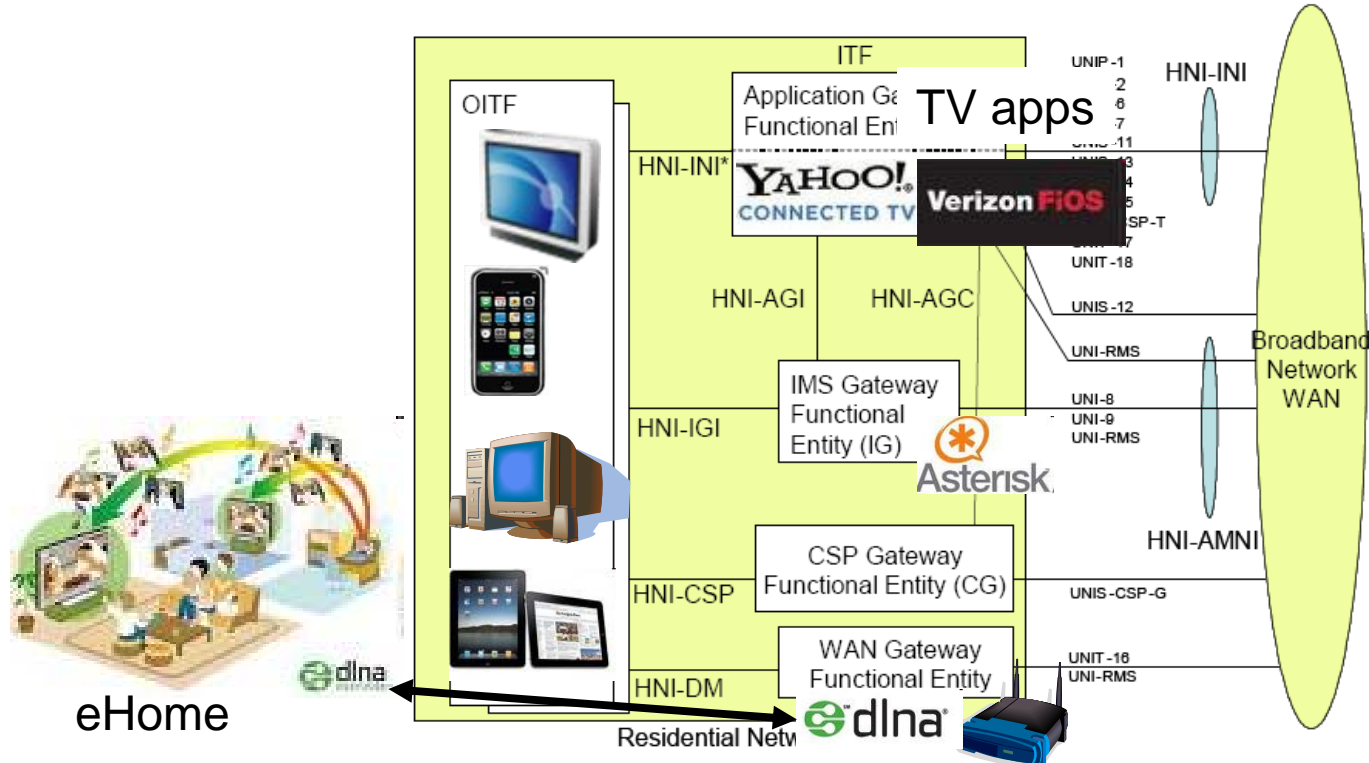
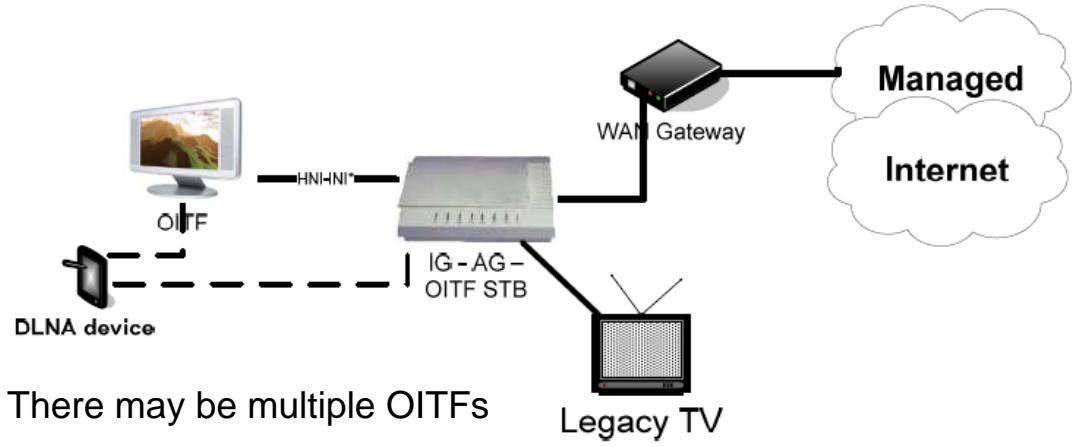

Figure 5-3: Residential Network Architecture

openIPTVForum home network configurations

5.3.4.2.8 Combined IG-AG-OITF STB and OITF TV



There may be multiple OITFs

5.3.4.2.9 Combined AG-IG with multiple OITFs

