

Towards a Mobile Network of Information and Services

5th KuVS GI/ITG Workshop on NG Service Delivery Platforms

*DOCOMO Eurolabs Munich
2011-10-11*

Dirk Kutscher – NEC Laboratories Europe

EU-FP7 Project SAIL

Mobile Data Traffic Prediction

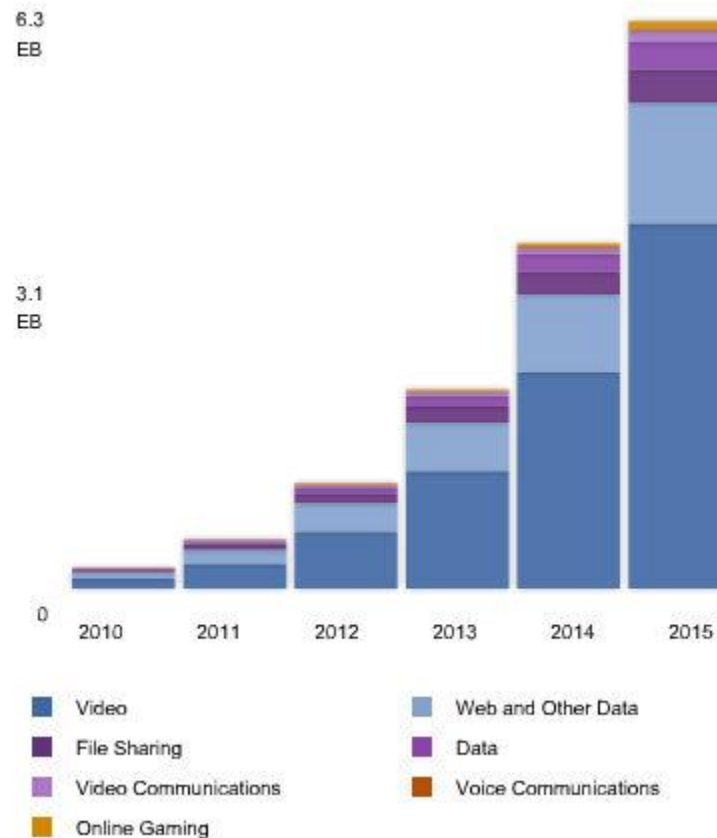

From 2010 to 2015:
factor 26 increase
expected

*Cisco VNI June 2011

Video Data Traffic Prediction

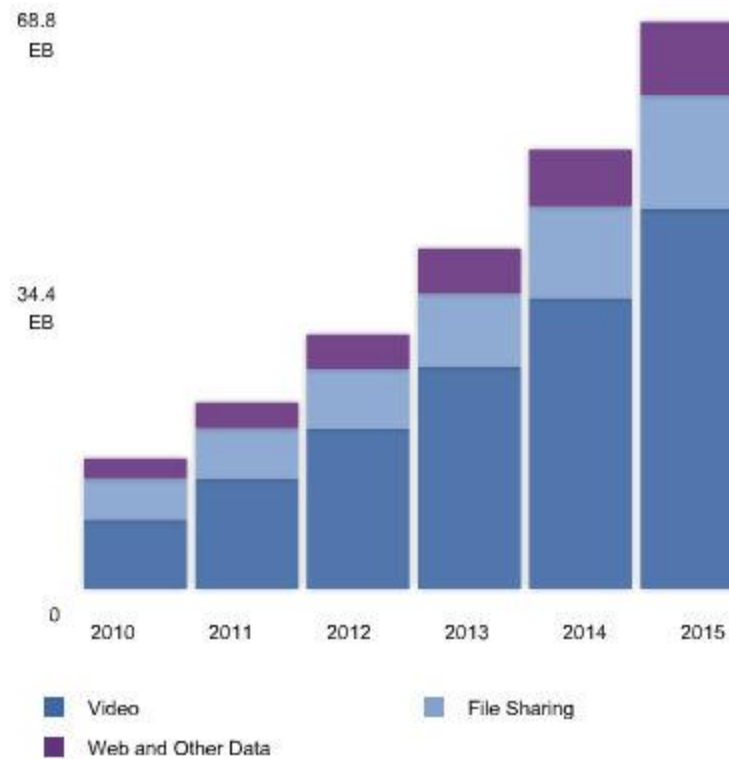

From 2010 to 2015:
factor 5 increase
expected

*Cisco VNI June 2011

Popular Conception:

Content Distribution Over the Internet Does Not Scale

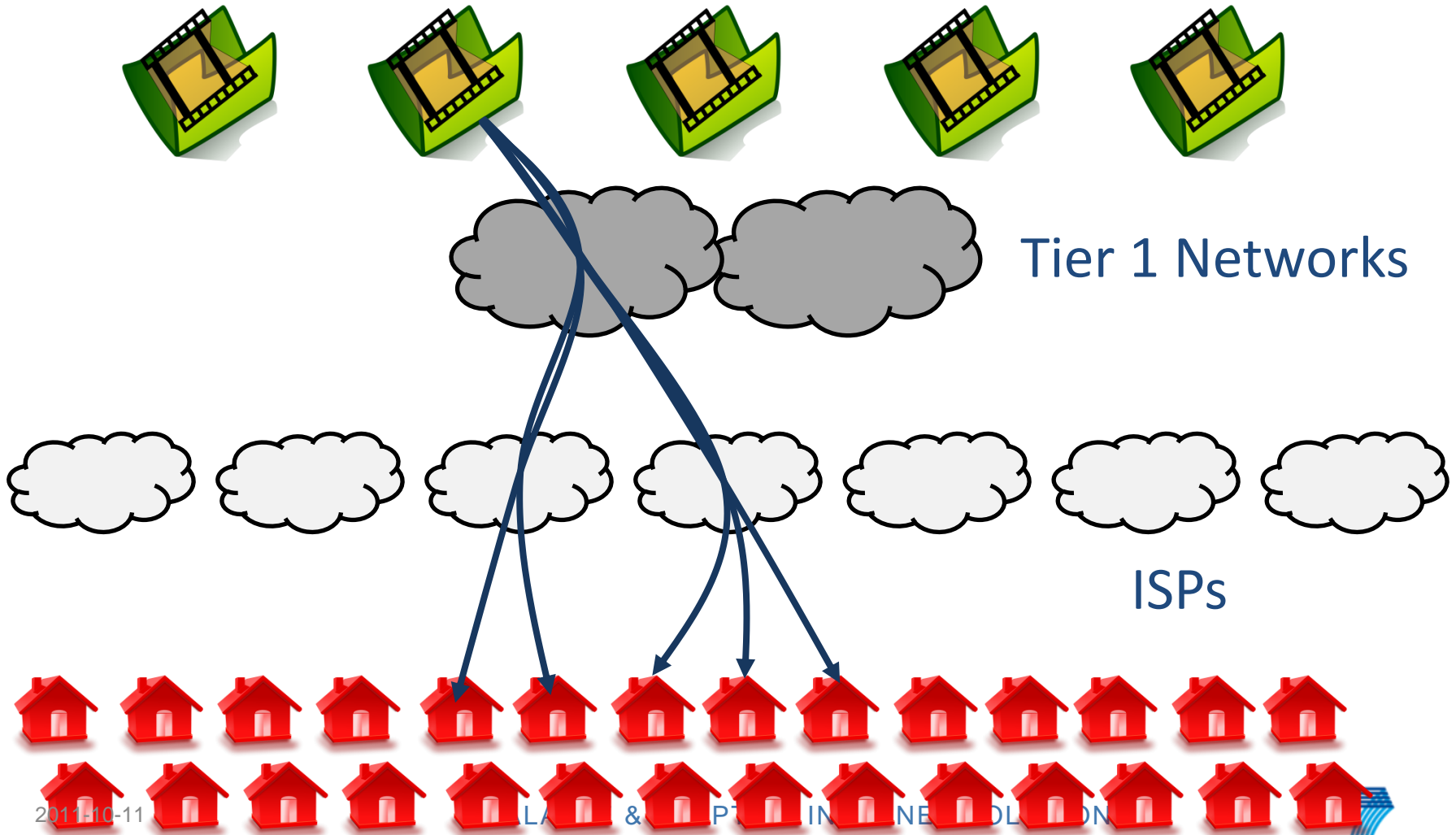

Problems with Today's Networks



- URLs and IP addresses are overloaded with locator and identifier functionality
 - Moving information = changing it's name => 404 file not found
- No consistent way to keep track of *identical copies*
 - No consistent *representation of information* (copy-independent)
- Information dissemination is inefficient
 - Can't benefit from existing copies (e.g. local copy on client)
 - No “anycast”: e.g., get “*nearest*” copy
 - Problems like *Flash-Crowd effect, Denial of Service, ...*

Problems with Today's Networks



- Can't trust a copy received from an untrusted node
 - Security is host-centric
 - Mainly based on *securing channels* (encryption) and *trusting servers* (authentication)

- Application and content provider independence
 - CDNs focus on web content distributions for major players
 - What about other applications and other players?
 - **What about services?**

Information-Centric Networking



Today's Internet

Focus on
nodes

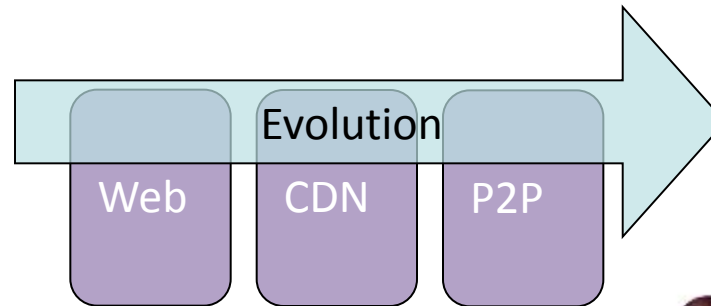
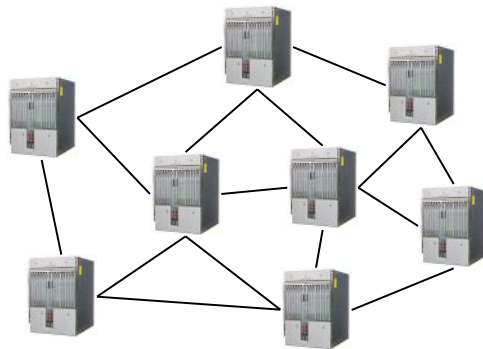

Future
Information-centric Network

Focus on
*information objects and
real world objects*

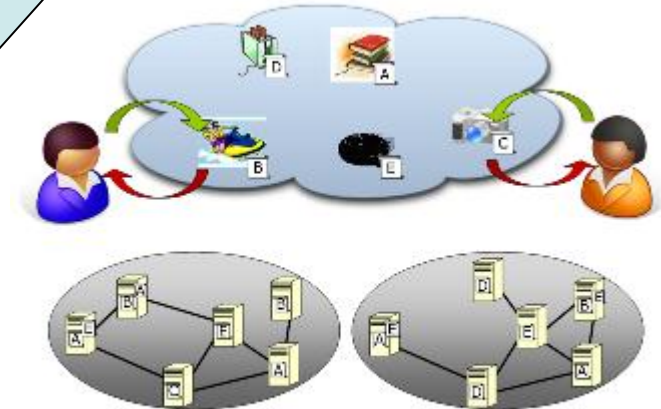

In today's Internet,
accessing information is
the dominating use case!

Scalable Adaptive Internet Solutions

On-demand usage of network resources

- **Cloud Networking:** Tying Cloud Computing and Network Virtualization together
- **Open Connectivity:** Efficient use of multi-path, multi-protocol and multi-layer networking – over any fixed and mobile networks
- **Network of Information:** Access to named information as a principal network service

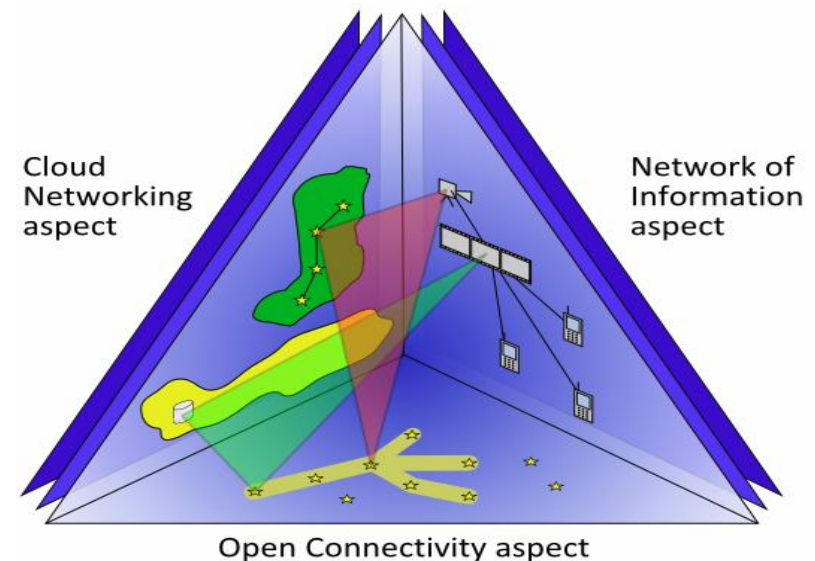

SAIL Network of Information



- Take information-centric networking to the next level
 - General-purpose information-centric architecture
 - Generalize CDN and P2P benefits to be integral part of network services
 - Commoditize application level content distribution
 - ...for a broad range of applications

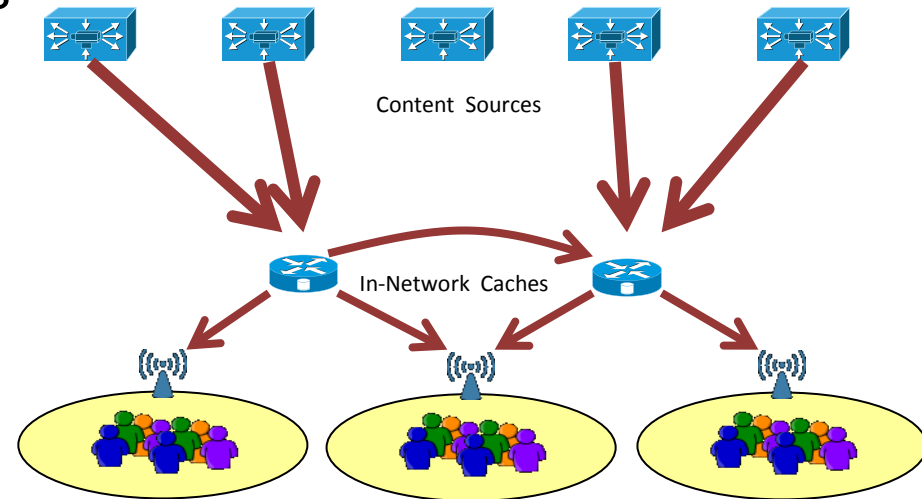

- Concrete benefits
 - A natural solution for today's eminent applications
 - An efficient and cost-effective infrastructure for the next wave of Internet adoption
 - Enabling new types of applications, services, and interaction forms

Web-based Information Retrieval

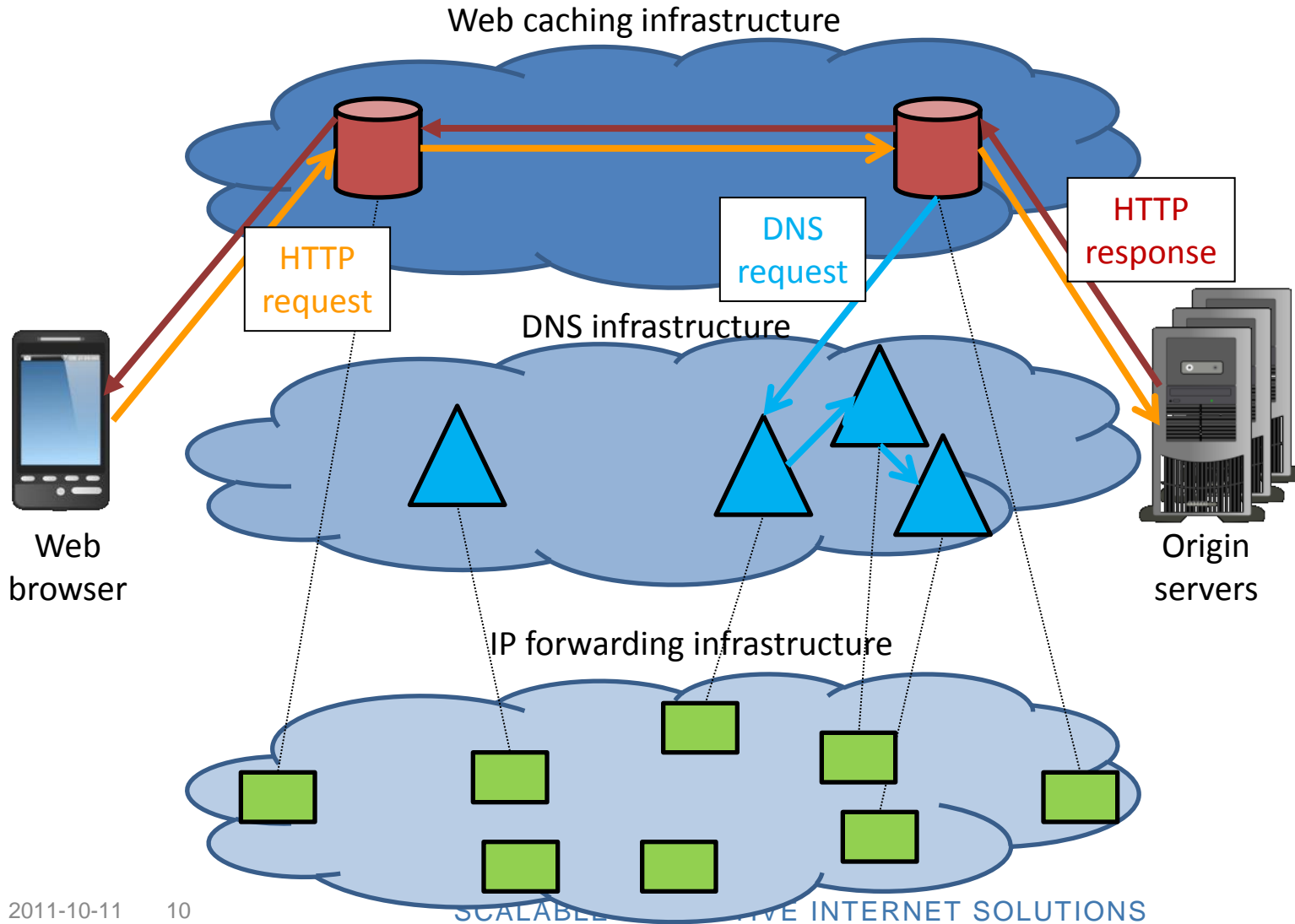

Web-based Information Retrieval

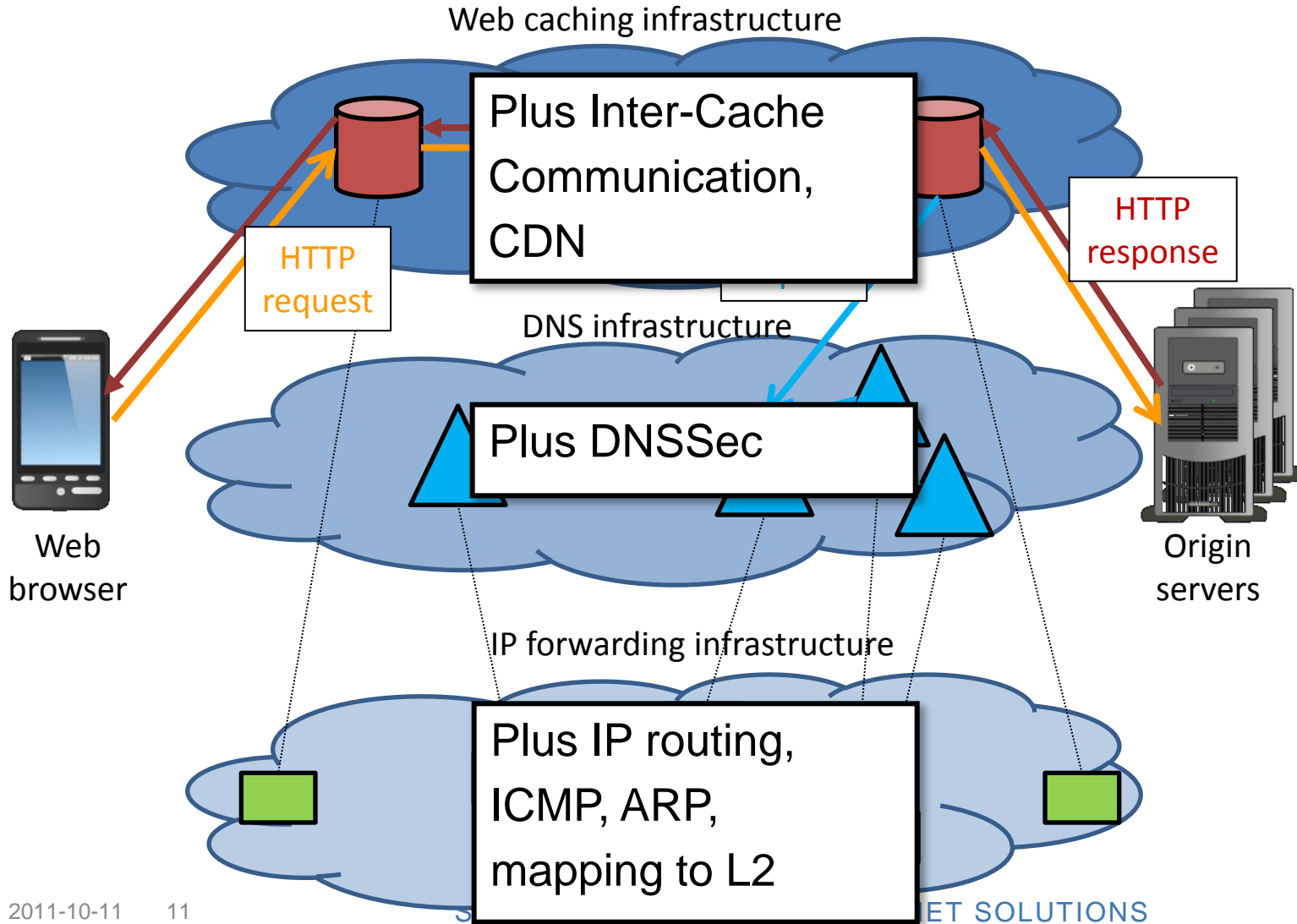

ICN-based Information Retrieval

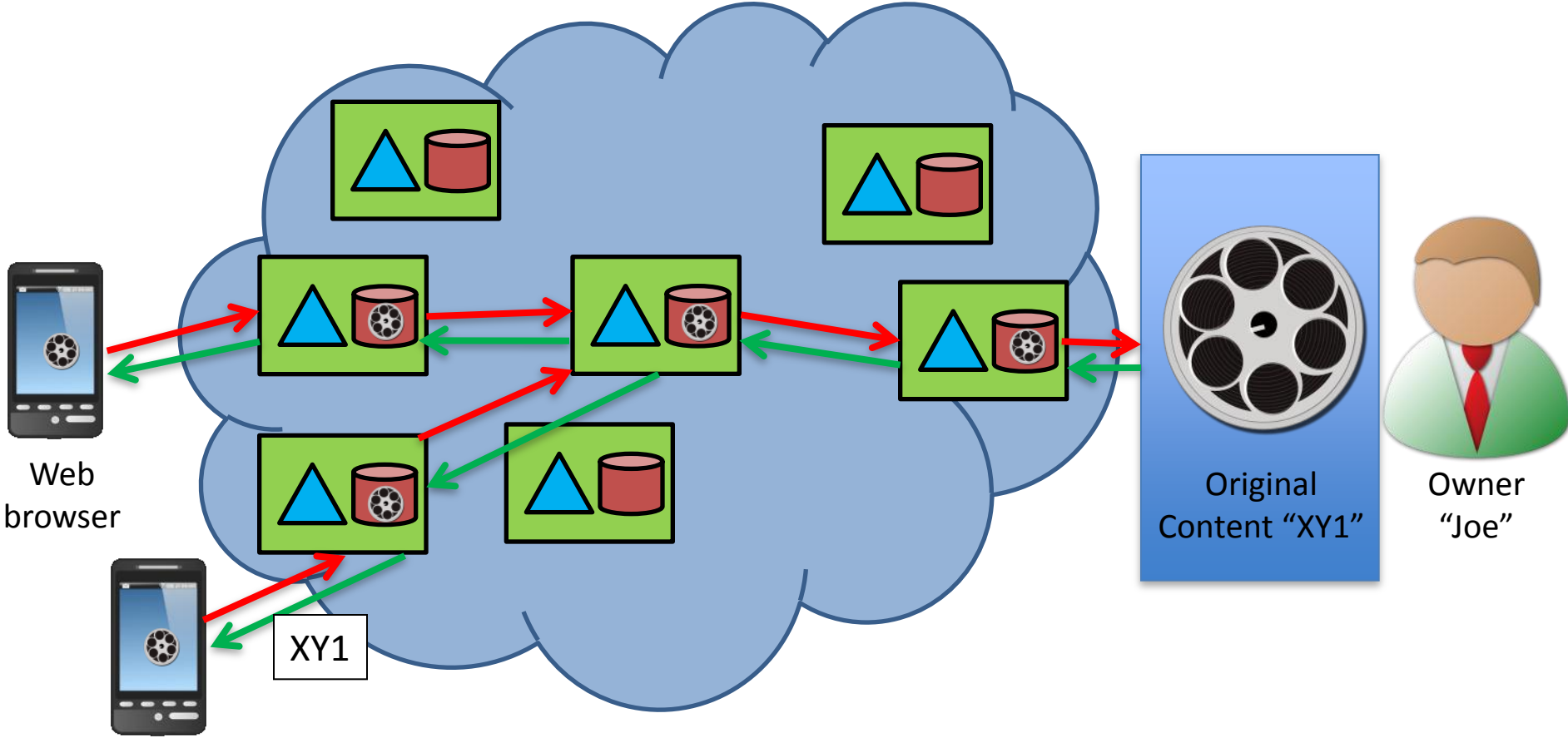

Challenges for ICN

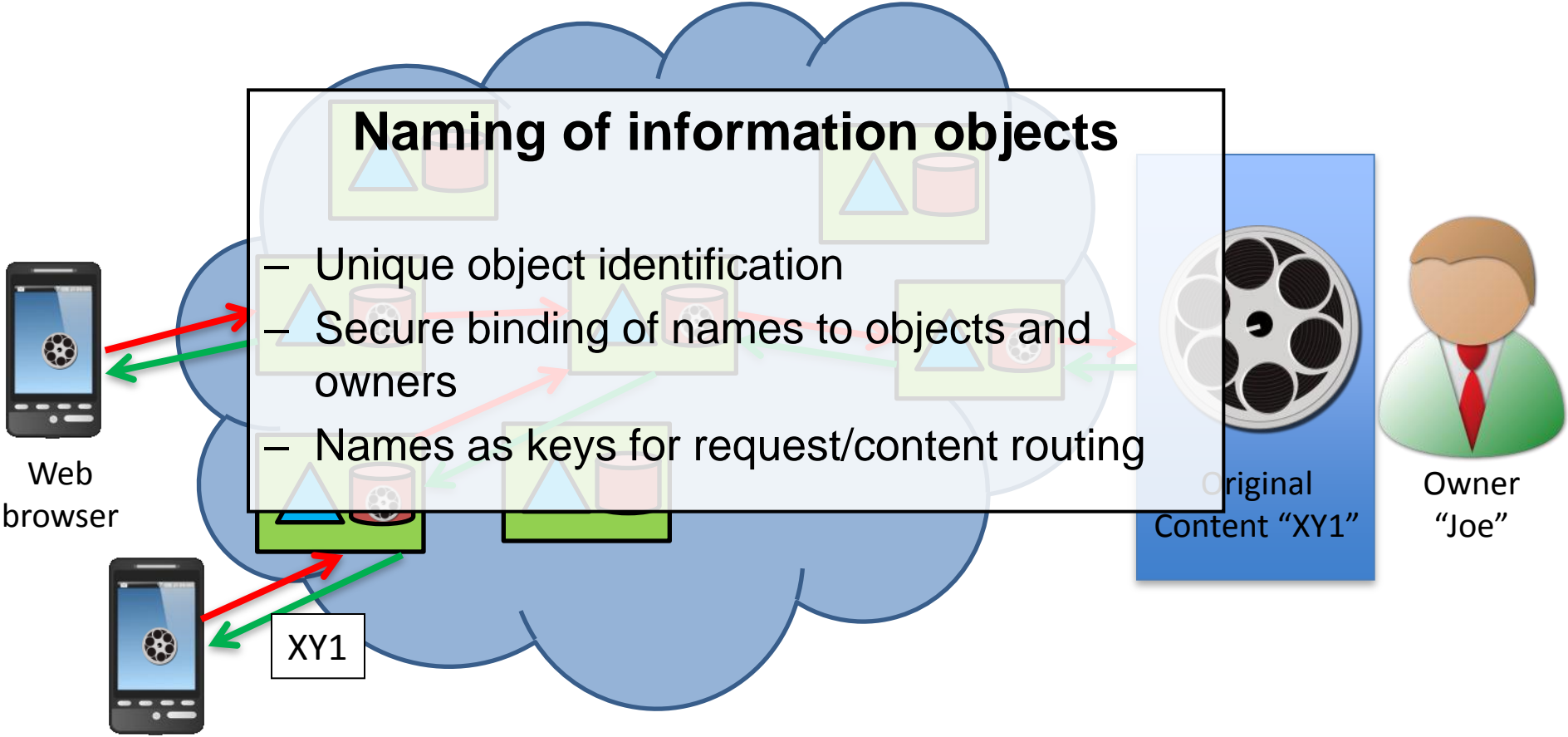

Routing and Name Resolution

- Want to locate “best” copy of named objects
- Need a mapping/link between named objects and underlying network topology
- Want to support mobility and multi-homing
- Name-based forwarding: forward on names (based on corresponding routing protocol)
- Name resolution: resolve names to locators (leveraging underlying forwarding and routing infrastructure)



Web browser

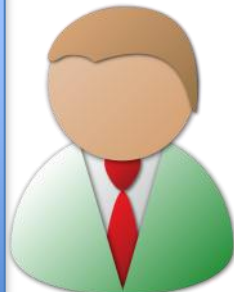

Owner
“Joe”

Resource Management and Transport

- Reliable, congestion- and flow-controlled transport of objects from a given location to interested receiver
- Good support for caching, multi-path, disruption tolerance
- Options
 - Receiver-oriented transport
 - End-to-end vs. hop-by-hop



Web browser



XY1

Original Content "XY1"

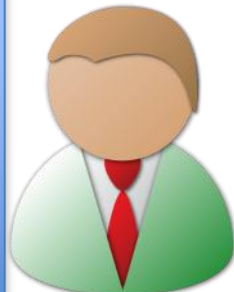

Owner "Joe"

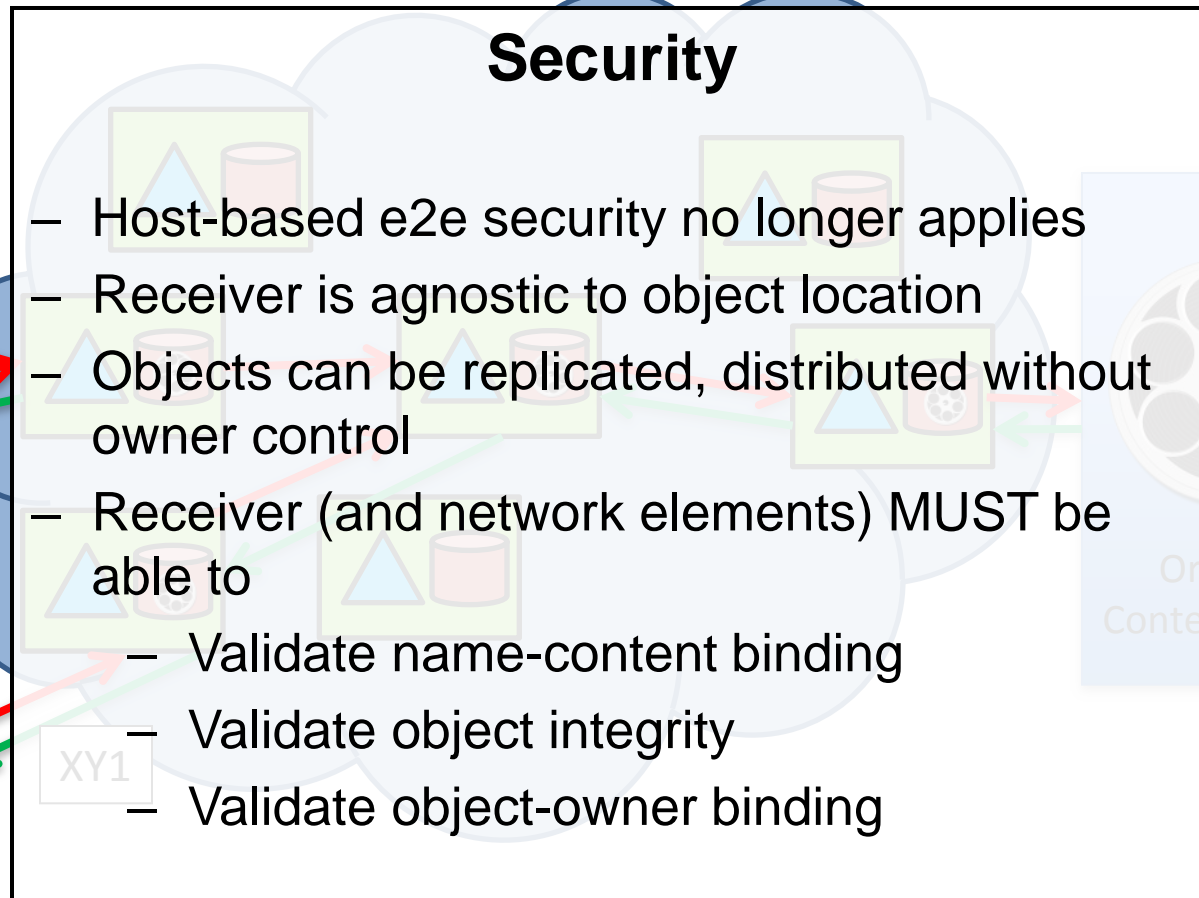

Web browser



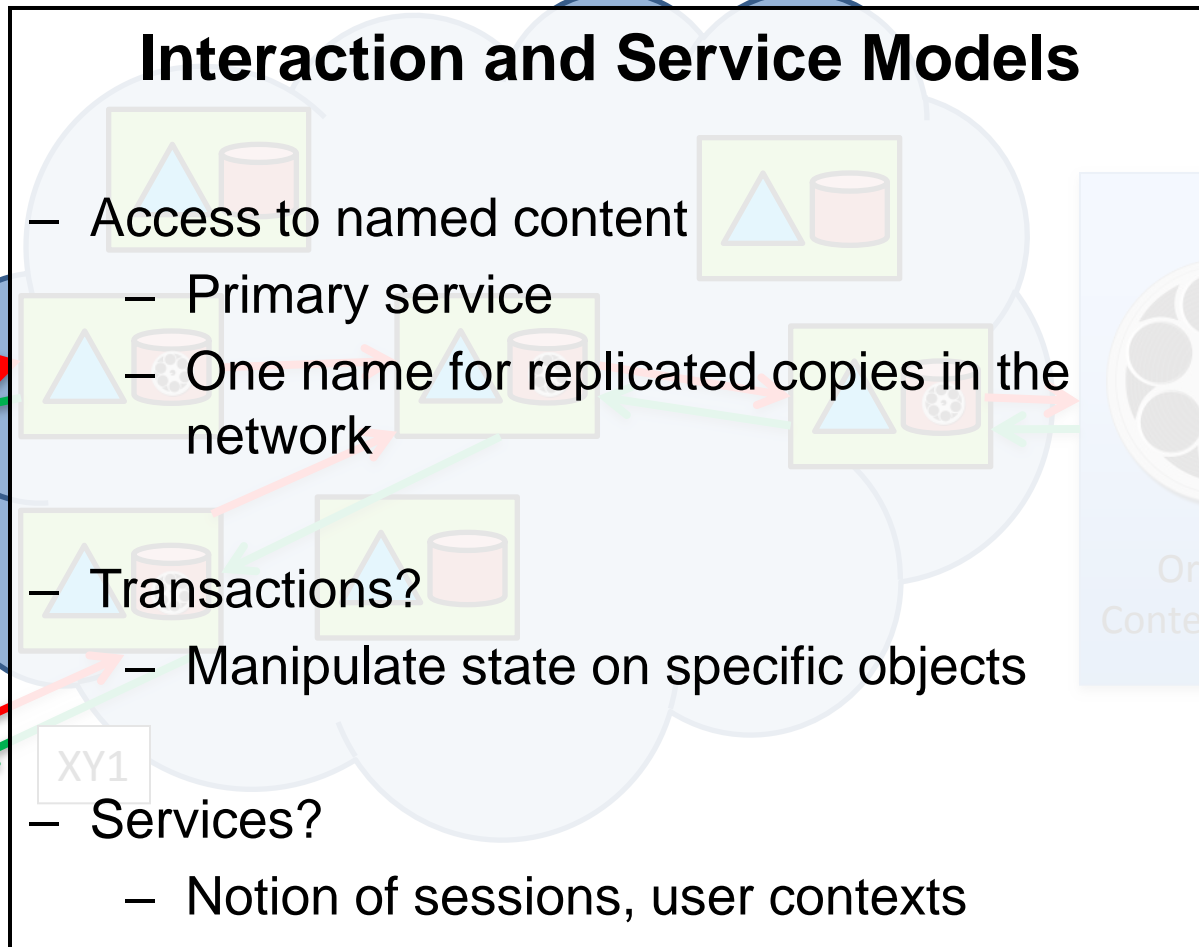

Heterogeneous Network of Information

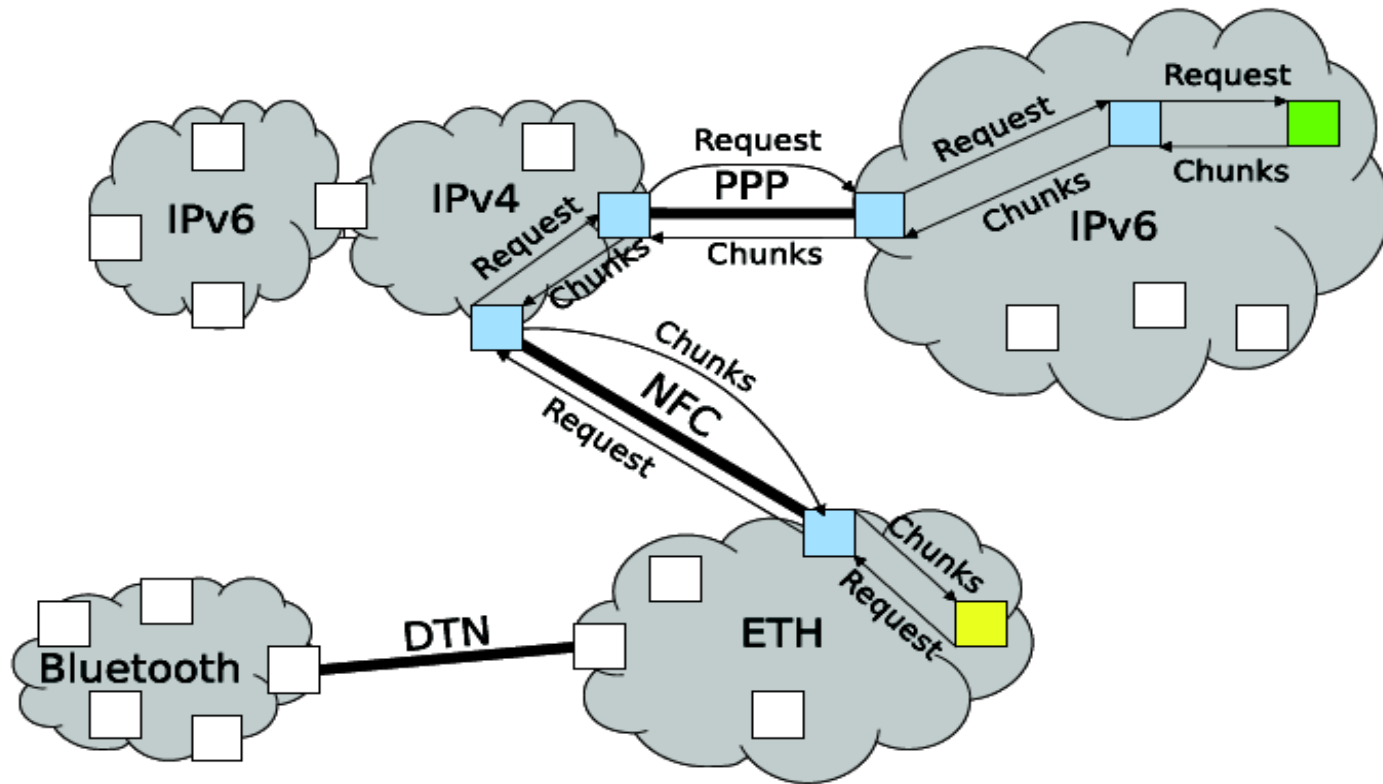

Requester

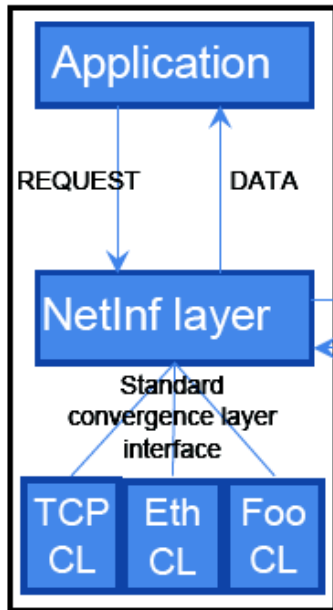

NRS - Name Resolution System nodes
NR - NetInf Router nodes
CL - Convergence Layer

Publisher

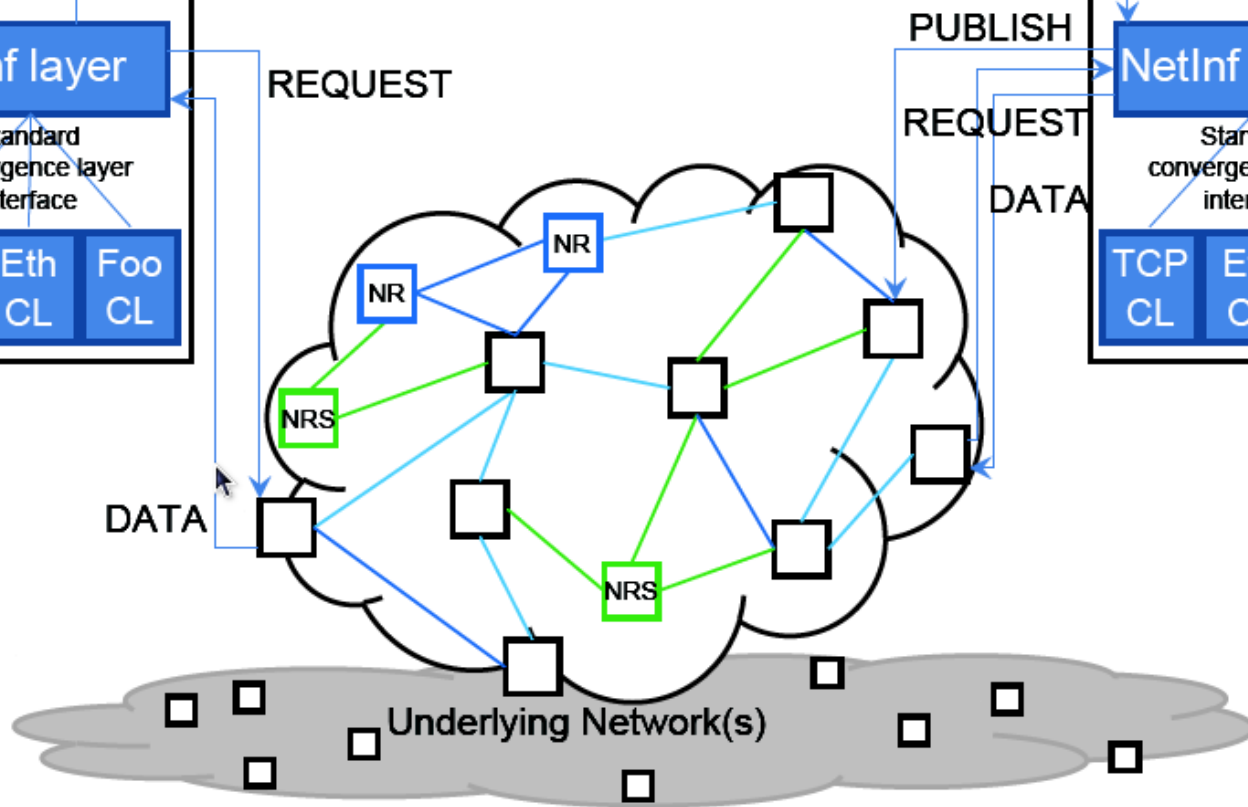
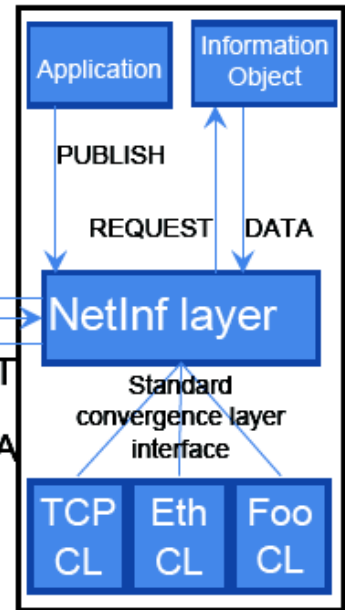

NetInf Naming



- Internet Draft draft-farrell-ni
- “Minimalist” approach, only specifying name form but not resolution nor routing nor much else
 - But enabling various forms of those
- Basic idea: generic URIs for hash function outputs
 - Naming the hash function, the hash verification Input and its interesting payload, e.g. some kind of self-signed object (ssobj) that contains a JPEG image

```
ni:///nec.de/dirks-webcam
```

```
ni:///tcd.ie/ssobj:jpeg:sha256:  
NDVmZTMzOGVkY2JjZGQ0ZmNmZGF1ODQ5Mjky  
ZDM0ZTg2ZDI5YzllMmU5OTFlNmE2Mjc3Z
```

Name Resolution Design Space



- Domain Name System (DNS)
 - Requires hierarchical namespace to scale

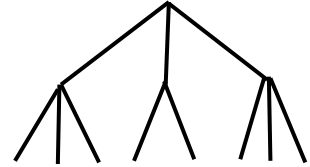

- Distributed Hash Table (DHT)
 - + Scalable for flat namespaces
 - Higher latency for global DHT
 - Difficult to select close copy
 - System has no topological information

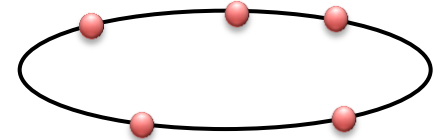

- Hierarchical DHT (Hierarchy of DHTs)
 - + Hierarchy: increase *robustness*, reduce *latency*
 - Solving diff. problem: How to find *responsible node* vs.: Find the *best/closest copy*
 - No efficient network usage

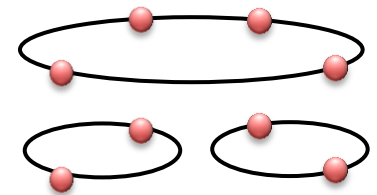

→ Idea: Use hierarchy to increase network efficiency

NetInf Name Resolution: Hierarchical NRS for Flat Namespaces



System-independent approach:

1. Resolution domains
 - Administrative autonomy: Simplify deployment
 - One or more resolvers, potentially interconnected via DHT
2. Build hierarchy of resolution domains
 - Topologically embedded: *enabler* for low latency, network efficiency
3. Inter-domain routing/forwarding scheme
4. Scheme to (a) *register* and (b) *request* objects
 - Essential for *low latency* and *efficient network usage*

→ One specific implementation: MDHT

D'Ambrosio, Dannewitz, Karl, Vercellone; **MDHT: A Hierarchical Name Resolution Service for Information-centric Networks**; ACM SIGCOMM 2011 ICN Workshop; August 2011

(1, 2) MDHT – Hierarchy of Resolution Domains

- Designed as infrastructure network
- Topologically embedded
 - On following slides: logical view
- Nested design → fast, robust inter-domain forwarding
- Heterogeneous → supports different DHT variants
- Also supported: asymmetry, different depth, more levels, ...

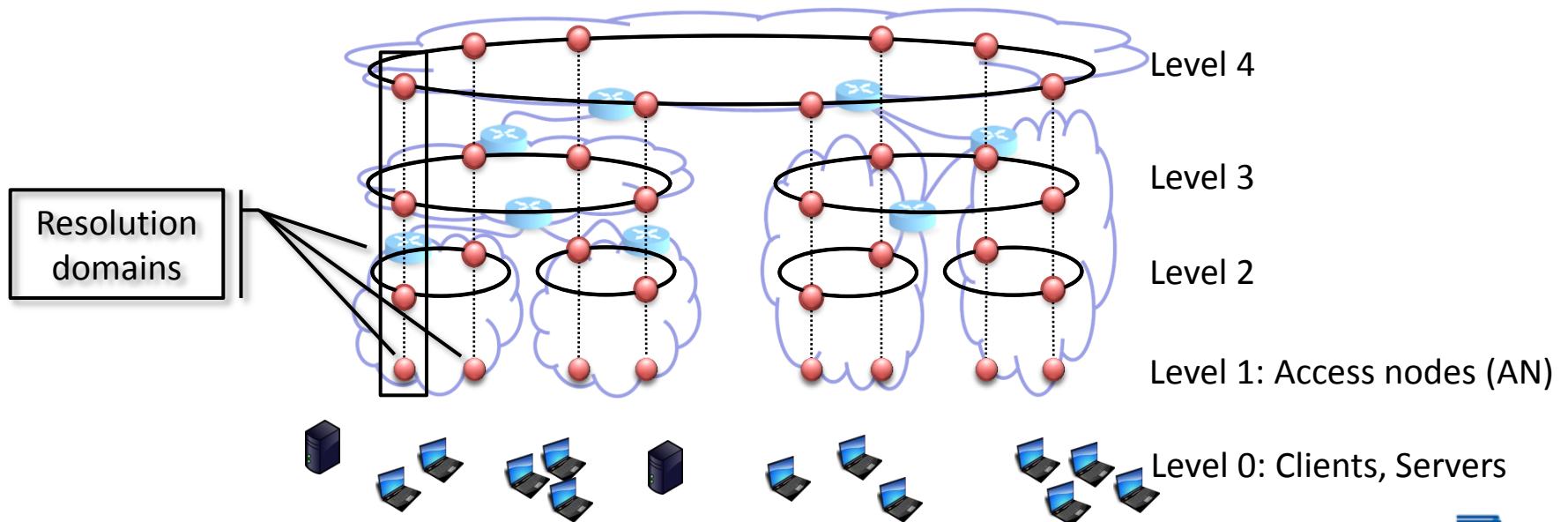

Service Program Mobility

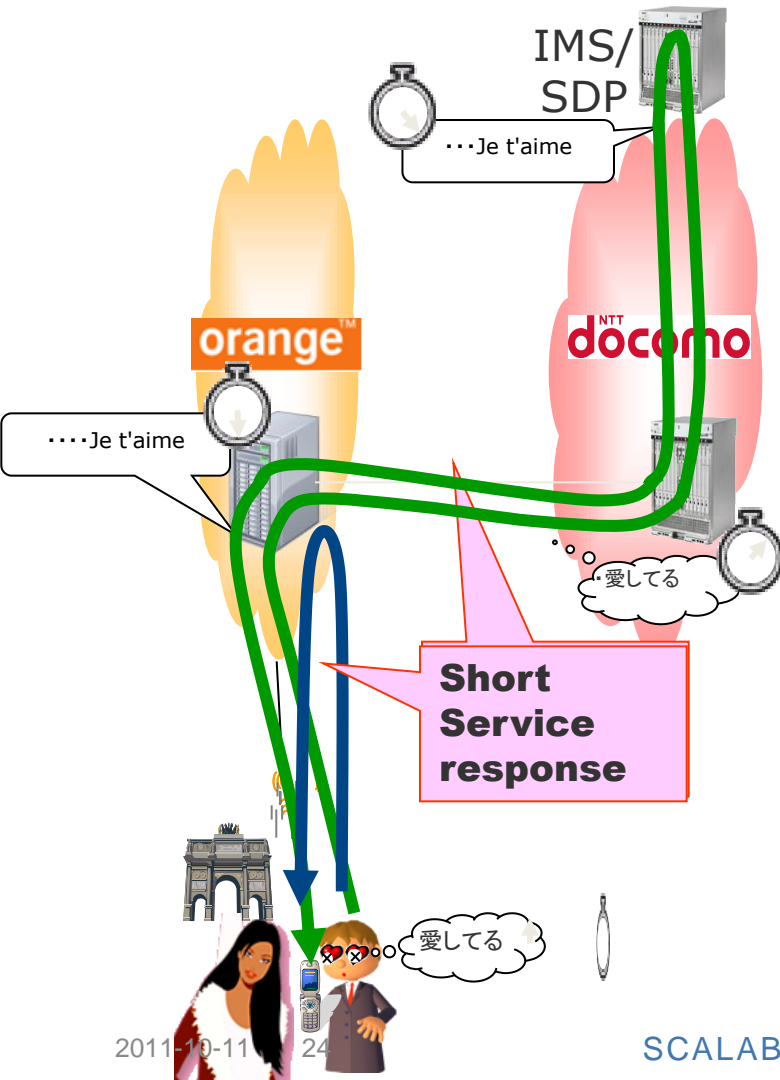

2011-10-11 24

SCALABLE & ADAPTIVE INTERNET SOLUTIONS



Service Program Mobility

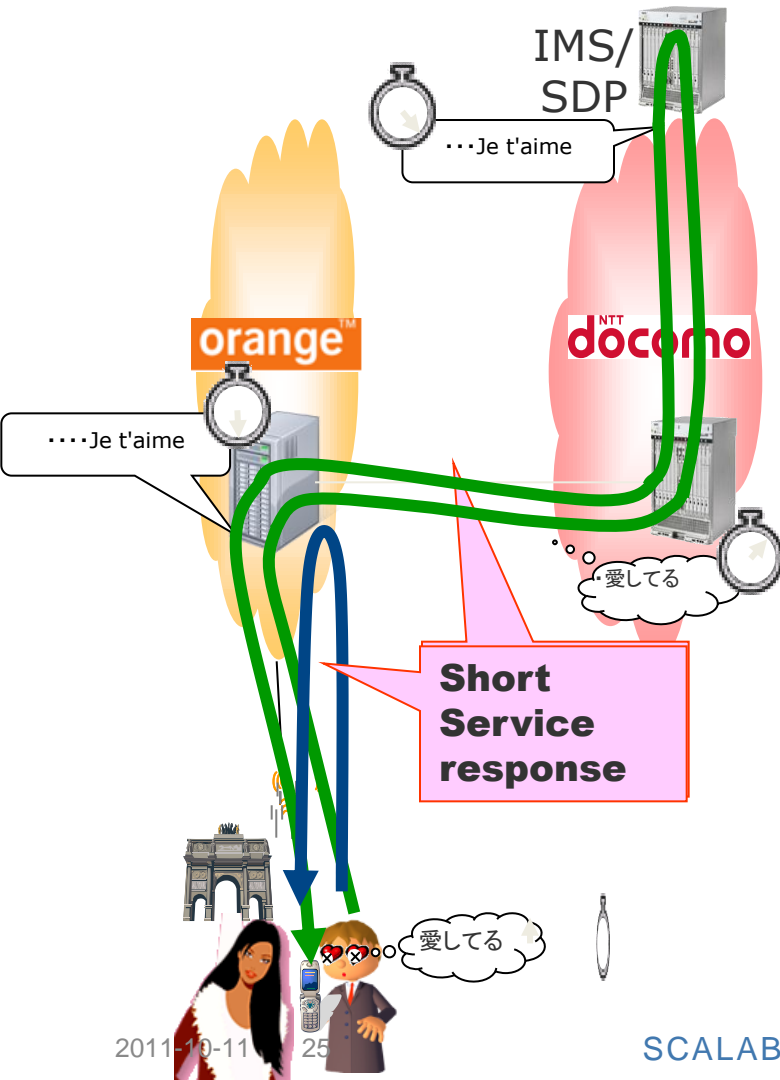

Benefits

- Improved user satisfaction
- Better usage of network resources
- Service-centric globalization
- Service failure prevention/ disaster recovery

Main System Components

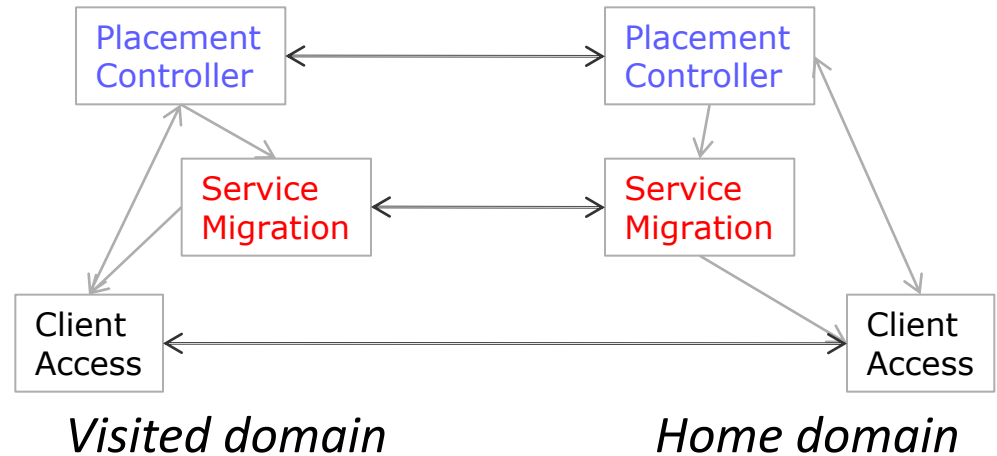

Services in a Network of Information



- Enablers
 - Services as the main elements for networking
 - Services and content can move
 - Design algorithms for service/content placement, lookup, transport and migration
- Service platforms and migration
 - Leveraging cloud networking concepts
 - Virtualized execution platforms and communication resources

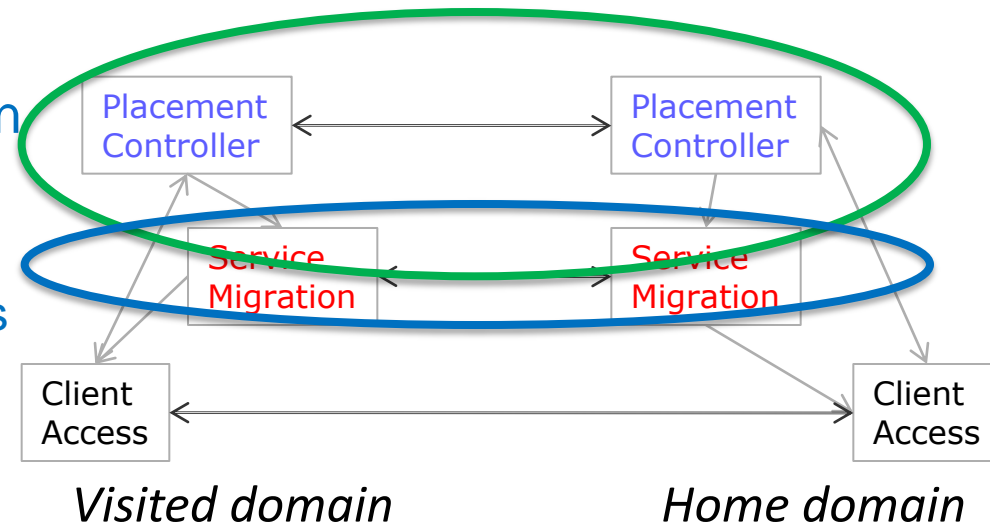

Summary and Discussion



- Information-Centric Networking: accessing named content and services as a first-order networking principle
- A general purpose platform for different applications
- Different take on service platforms: integrate execution into general object/service model
- **Discussion: Information-Centric Networking and Service Delivery Platforms – a natural next step or too far a stretch?**

Empowered by Innovation

NEC

<http://www.sail-project.eu/>

<http://www.dirk-kutscher.info/>